

KAMTECH

TEKNOLOJİK MAKİNALAR SAN. TİC. LTD. ŞTİ.

KAM

MÜHENDİSLİK

KAMMAX

GROUP

Yerleşim ve Personel

- Eskişehir OSB Oto Sanayiciler Sitesi A –Blok No : 9-12
- Kapalı Alan 720 m²
- 4 ü Ar-Ge Mühendisi Toplam 6 Mühendis
- Toplam 22 Çalışan

FALİYET ALANLARI

- Özel Tasarım Makine İmalatı
- Robotlu Uygulamalar
- Hat Tasarımı ve Kurulumu
- Gıda Makineleri Tasarım ve İmalatı
- Alüminyum ve Çelik Boru İmalat Hatları
- Test Cihazları Tasarım ve İmalatı
- Fixture ve Mastar Tasarımı ve İmalatı
- Mühendislik ve Danışmanlık Hizmetleri
- Beyaz Eşya Yan Sanayii

ÇALIŞMA YÖNTEMİ

VERİ TOPLAMA



ARAŞTIRMA



KONSEPT TASARIM



MÜŞTERİ ONAYI



TEKLİF HAZIRLAMA



TEKLİF ONAYI

DETAY TASARIM



TASARIM GÖZDEN
GEÇİRME



TASARIM ONAYI



MALZEME TEMİNİ
VE İMALAT



MONTAJ

TEST VE DENEMELER



MÜŞTERİ ONAYI



DEVREYE ALMA



SAHA TESTLERİ



PROJE ONAYI

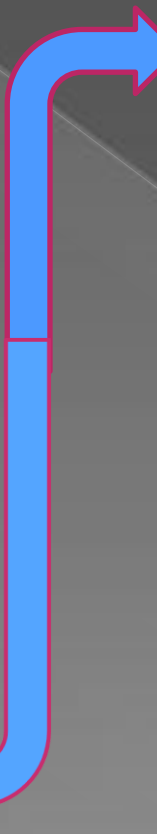

KAMTECH

TEKNOLOJİK MAKİNALAR SANAYİ TİC. LTD .STİ

Al Boru Üretim Hatları ve Boru Sarım Makinesi

- Aluminyum ve çelik boruların düzgün şekilde kangal halinde insansız sarım yapmayı sağlayan özel tasarım sarım makinesi .

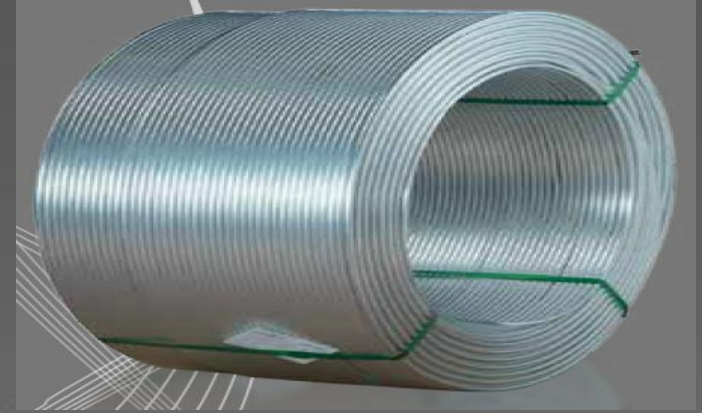

KAMTECH

TEKNOLOJİK MAKİNALAR SANAYİ TİC. LTD .STİ

Gaz Borusu Büküm Şekillendirme Makinası

- Hidrolik 4 İstasyonda Klasik Ocak Gaz Borularını Üreten Makine



Boru Şişirme Makinesi

Triming and Bending Makinası (Omera Tipi) ve Ürüne Uygun Kalıp Tasarımı

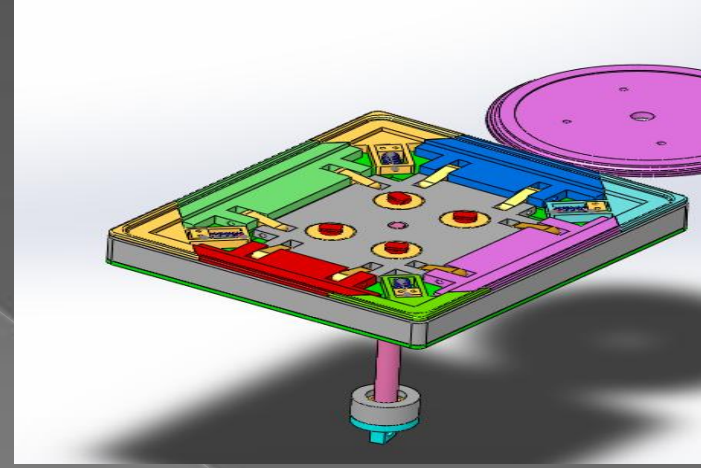
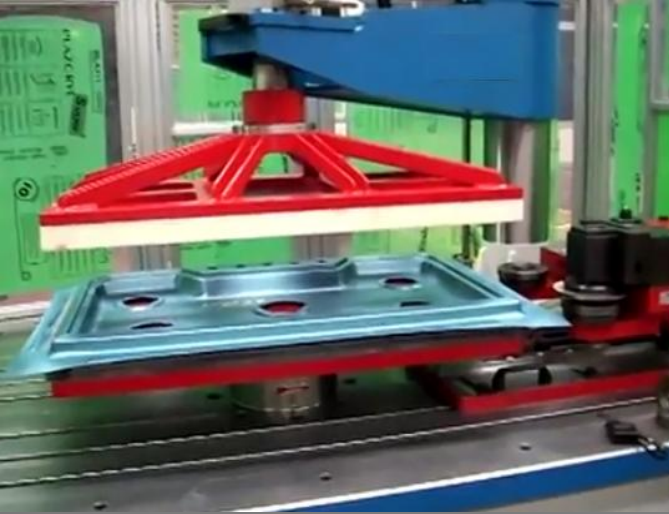

- Setüstü ve ankastre ocaklarda üst veya alt tablanın kenarlaması ve formlanmasını sağlamaktadır açılır kapanır kalıp özelliği

KAMTECH

TEKNOLOJİK MAKİNALAR SANAYİ TİC. LTD .STİ

Polyurethan Bantlı , Spiral ve Paletli Konveyörler



- ◉ İmalat , montaj , ısıtma , soğutma ve buffer amaçlı konveyörlerin tasarımı ve imalatı

KAMTECH

TEKNOLOJİK MAKİNALAR SANAYİ TİC. LTD. ŞTİ

Montaj Hattı İmalatı ve Kurulumu



KAMTECH

TEKNOLOJİK MAKİNALAR SANAYİİ TİC. LTD. ŞTİ

Montaj Hattı İmalatı ve Kurulumu

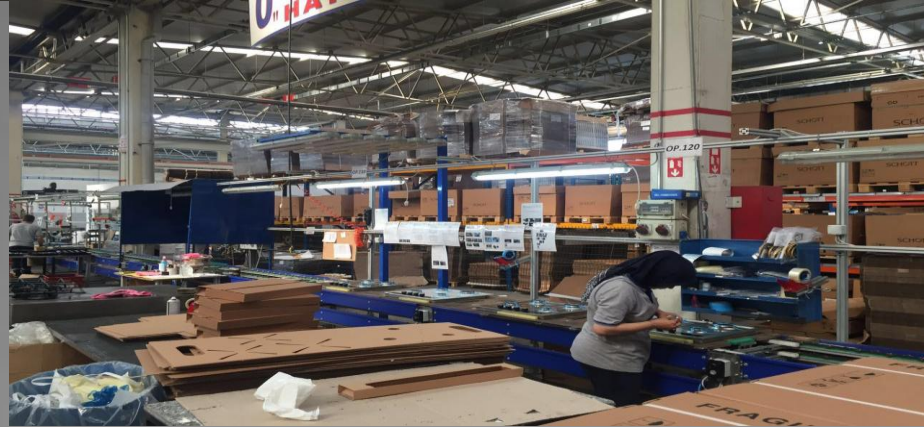

KAMTECH

TEKNOLOJİK MAKİNALAR SANAYİ TİC. LTD. ŞTİ

Montaj Hattı İmalatı ve Kurulumu



KAMTECH

TEKNOLOJİK MAKİNALAR SANAYİ TİC. LTD .STİ

Montaj Hattı İmalatı ve Kurulumu



KAMTECH

TEKNOLOJİK MAKİNALAR SANAYİ TİC. LTD .STİ

Fabrika Yerleşimi ve Hat Tasarımı

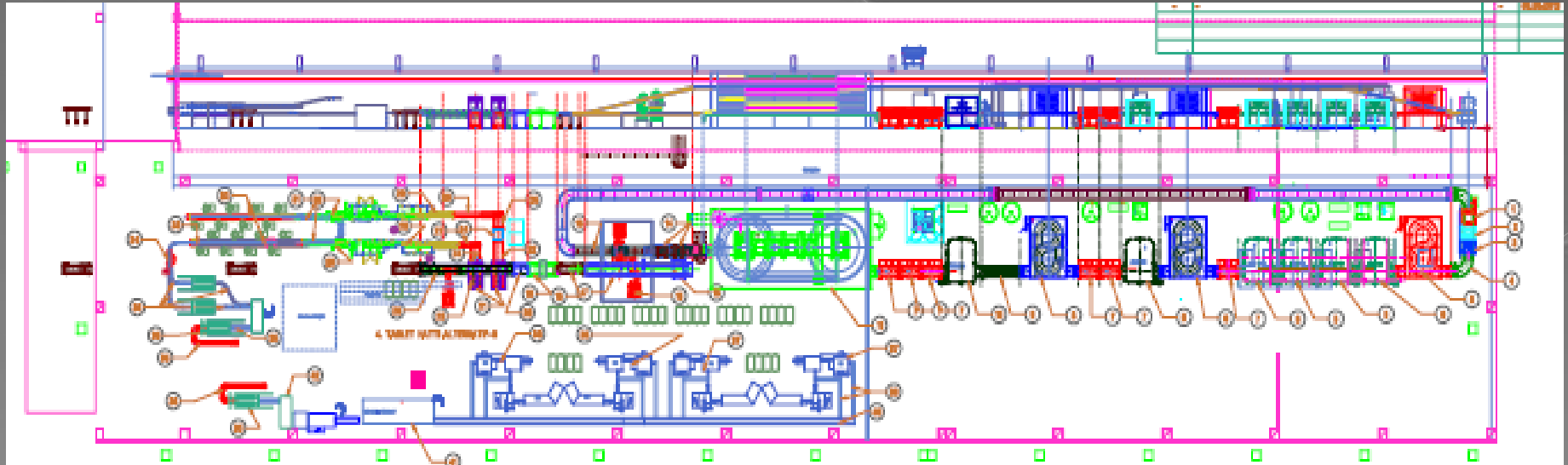
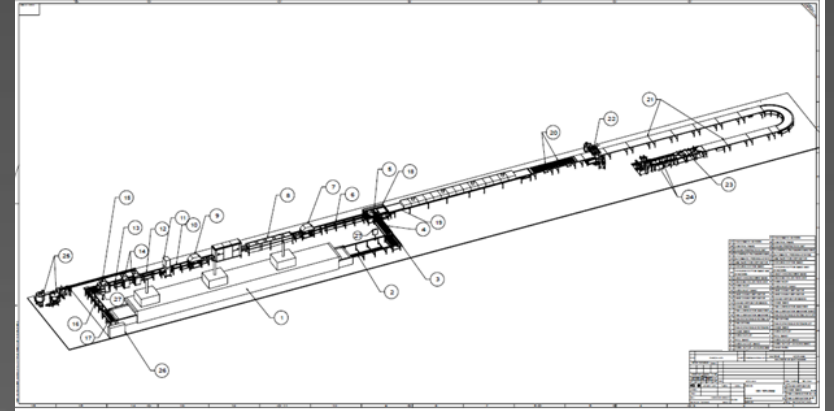
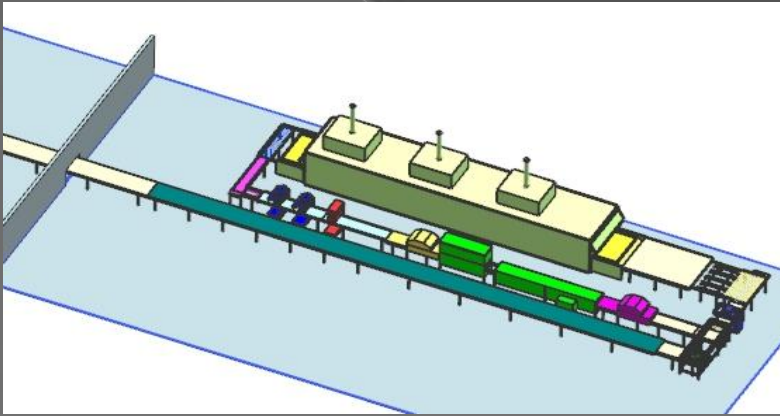

KAMTECH

TEKNOLOJİK MAKİNALAR SANAYİ TİC. LTD .STİ

Gofret ve Çikolata Hattı Makineleri



◉ Gofret Kremalama Makinesi

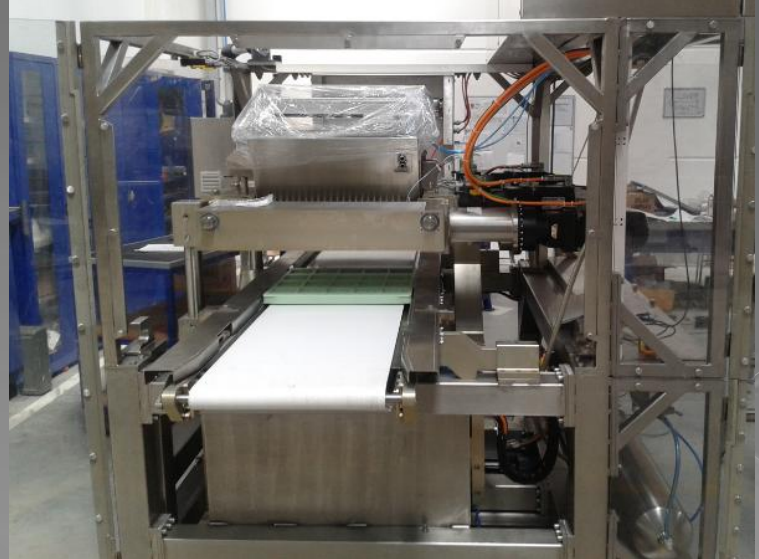

◉ CNC Decoratör , Depozitör

KAMTECH

TEKNOLOJİK MAKİNALAR SANAYİ TİC. LTD .STİ

Rotary Piston Reçel , Sos Enjekte Makinası

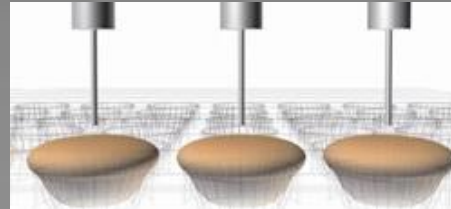
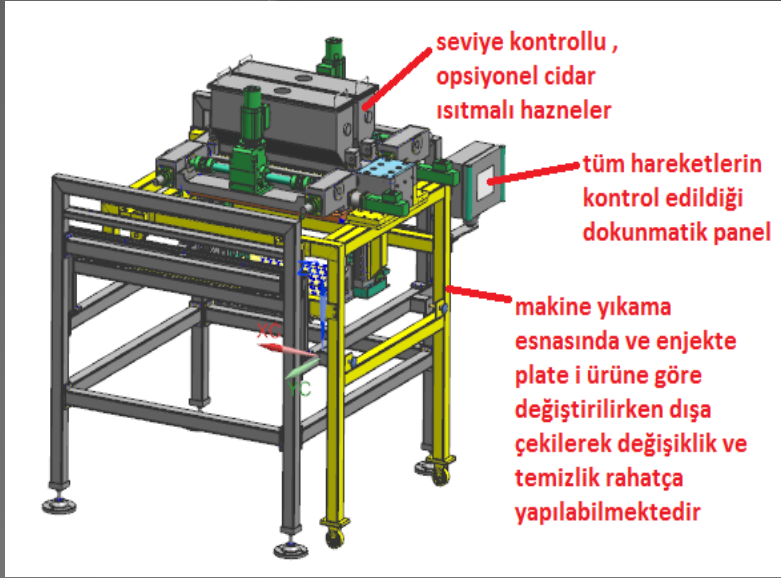

KAMTECH

TEKNOLOJİK MAKİNALAR SANAYİ TİC. LTD .STİ

Rotary Piston Hamur Depozitörü

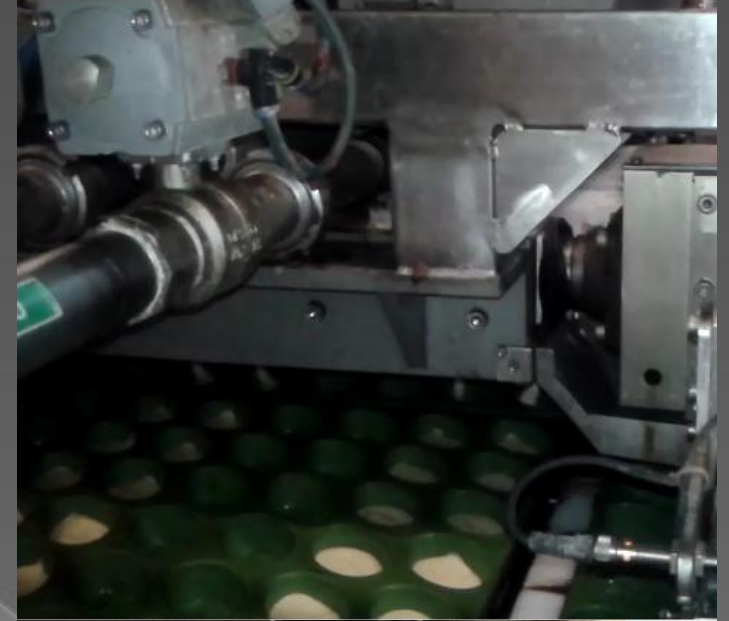

KAMTECH

TEKNOLOJİK MAKİNALAR SANAYİ TİC. LTD .STİ

OTOMATİK SOS SÜRME MAKİNASI



KAMTECH

TEKNOLOJİK MAKİNALAR SANAYİ TİC. LTD .STİ

Otomatik Gruplama Makinesi (Counter Feeder)

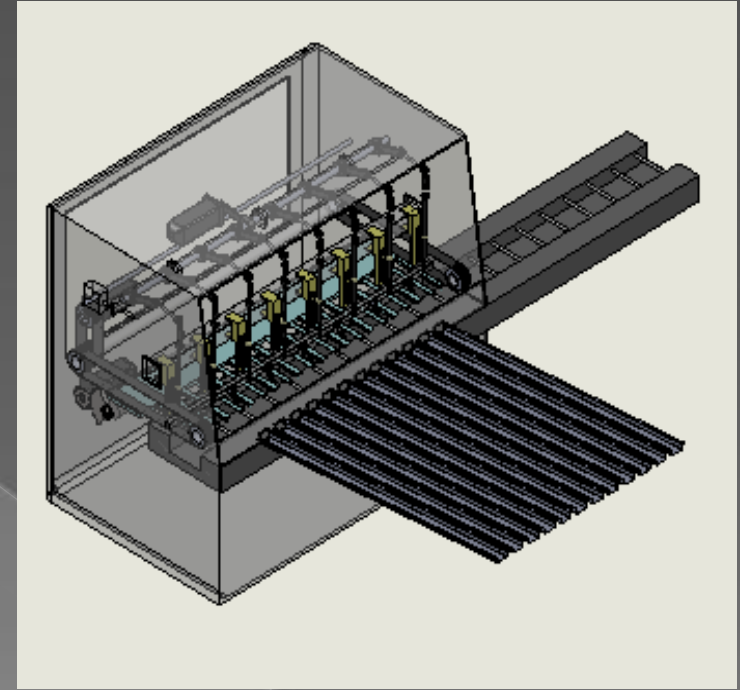

- ⦿ 8 Kanallı , 8 kanaldan sayarak veya volumetrik ayırarak ürünün paketleme makinası kuyruğuna teslimi . 80-100 pk /dk hız.

KAMTECH

TEKNOLOJİK MAKİNALAR SANAYİ TİC. LTD .STİ

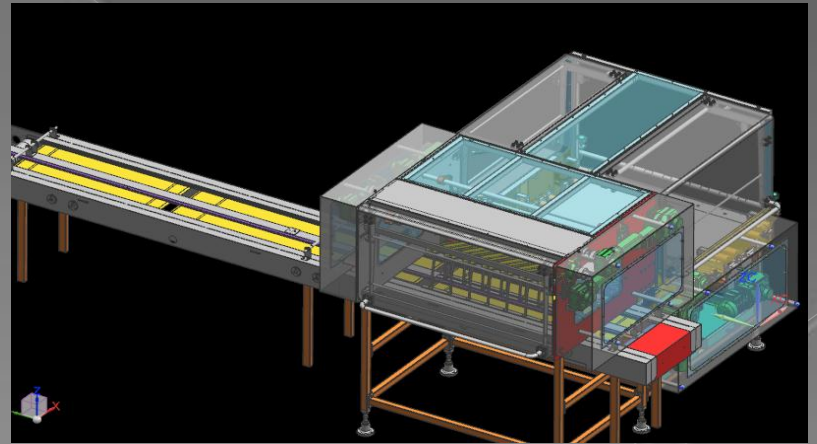
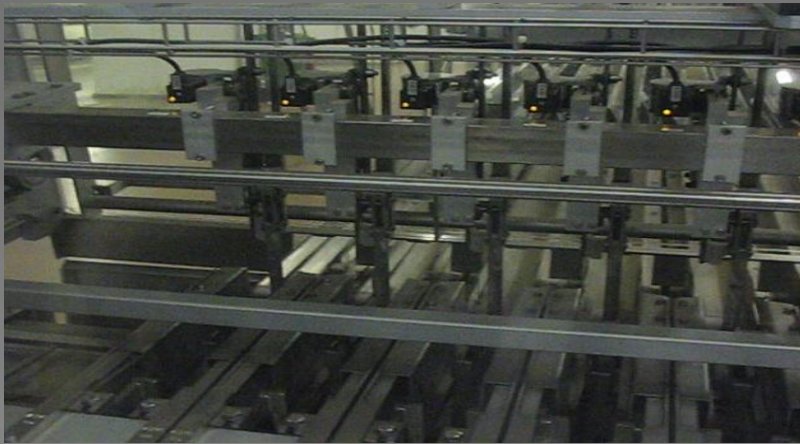

KAMTECH

TEKNOLOJİK MAKİNALAR SANAYİ TİC. LTD .STİ

CNC 2D /3D Lama ve Tel Büküm Makinası

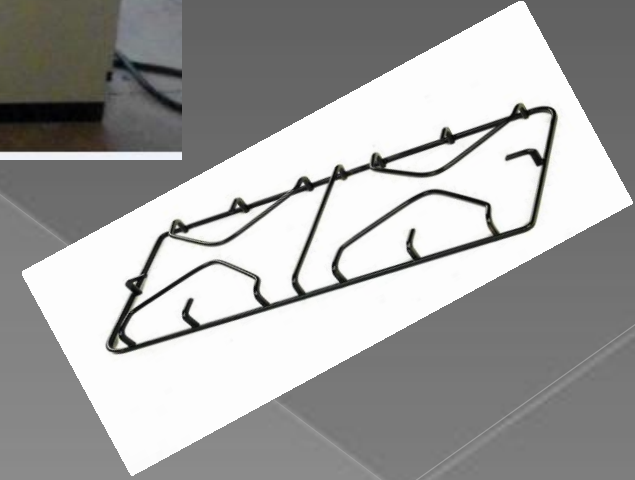
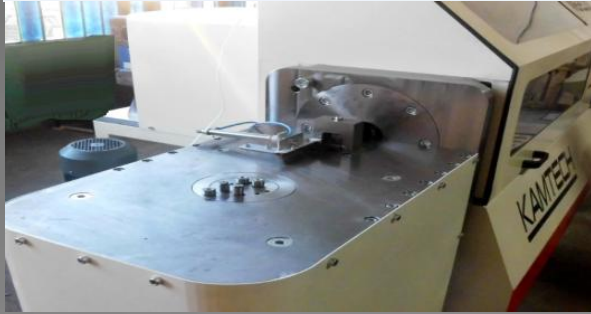

- ① 2 Eksenli ve 3 Eksenli Kılıcına ve yatay lama ve tel bükümü yapabilme

KAMTECH

TEKNOLOJİK MAKİNALAR SANAYİ TİC. LTD .STİ

CNC 2D /3D Lama ve Tel Büküm Makinası



KAMTECH

TEKNOLOJİK MAKİNALAR SANAYİİ TİC. LTD .STİ

Aluminyum Boru Kesim Makinası

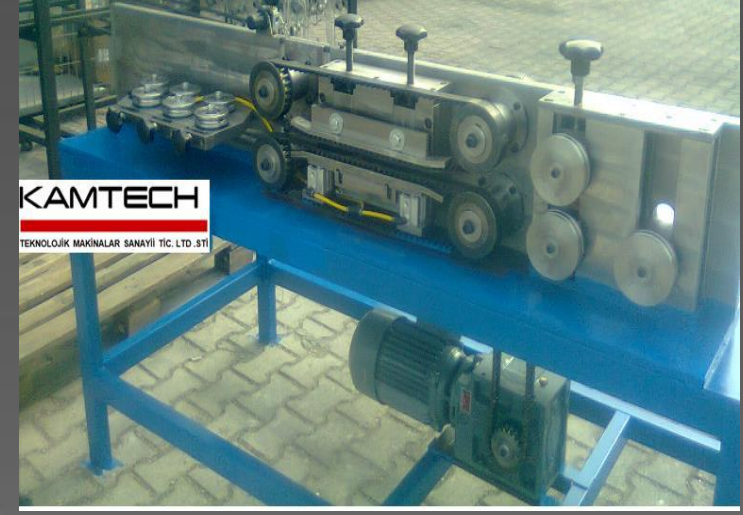
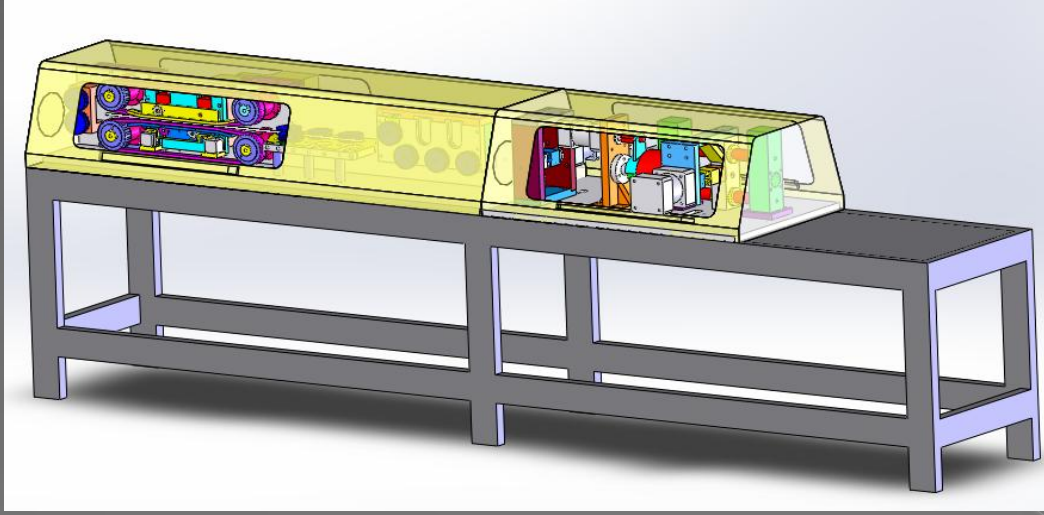

- Alüminyum boruyu 0.5 mm boy hassasiyetinde çapaksız , deforme etmeden kesebilme
- 1m ye kadar boydan bağımsız 60 adet/dk kesim hızı
- Servo kontrollü sürme sistemi

KAMTECH

TEKNOLOJİK MAKİNALAR SANAYİ TİC. LTD .STİ

GÖVDE KATLAMA-PUNTA MAKİNESİ



KAMTECH

TEKNOLOJİK MAKİNALAR SANAYİ TİC. LTD. ŞTİ

OTOMATİK BESLEMELİ HİDROLİK PRES 40 TON



KAMTECH

TEKNOLOJİK MAKİNALAR SANAYİ TİC. LTD .STİ

PINAR SÜT HAT SONU OTOMASYONU



KAMTECH

TEKNOLOJİK MAKİNALAR SANAYİ TİC. LTD .STİ

ARÇELİK



KAMTECH

TEKNOLOJİK MAKİNALAR SANAYİ TİC. LTD .STİ

Saint- Gobain Kelepçe Rollformu



KAMTECH

TEKNOLOJİK MAKİNALAR SANAYİ TİC. LTD .STİ

DD ÜST KAPAK ROLLFORM MAKİNASI

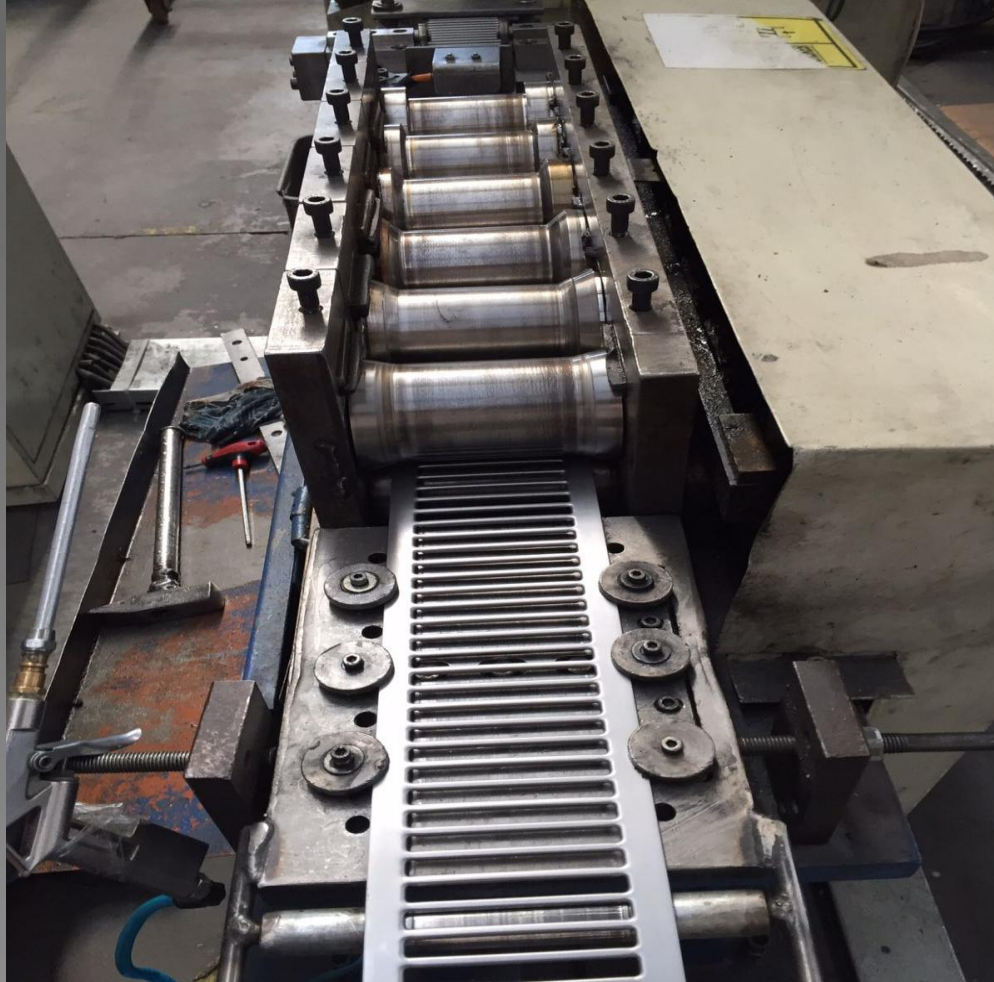

KAMTECH

TEKNOLOJİK MAKİNALAR SANAYİ TİC. LTD .STİ

ROBOT UYGULAMALARI

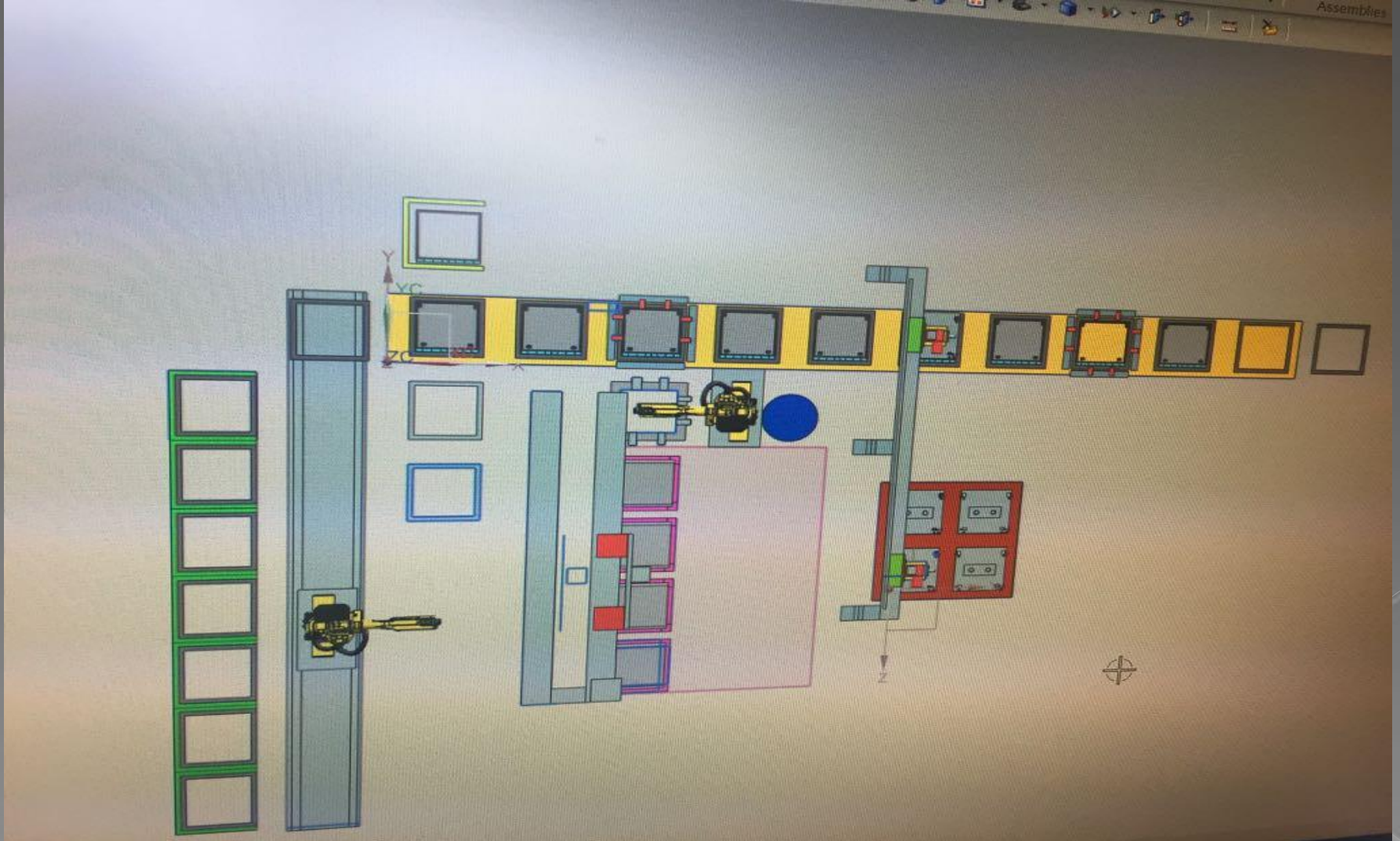

KAMTECH

TEKNOLOJİK MAKİNALAR SANAYİ TİC. LTD .STİ

ROBOT UYGULAMALARI

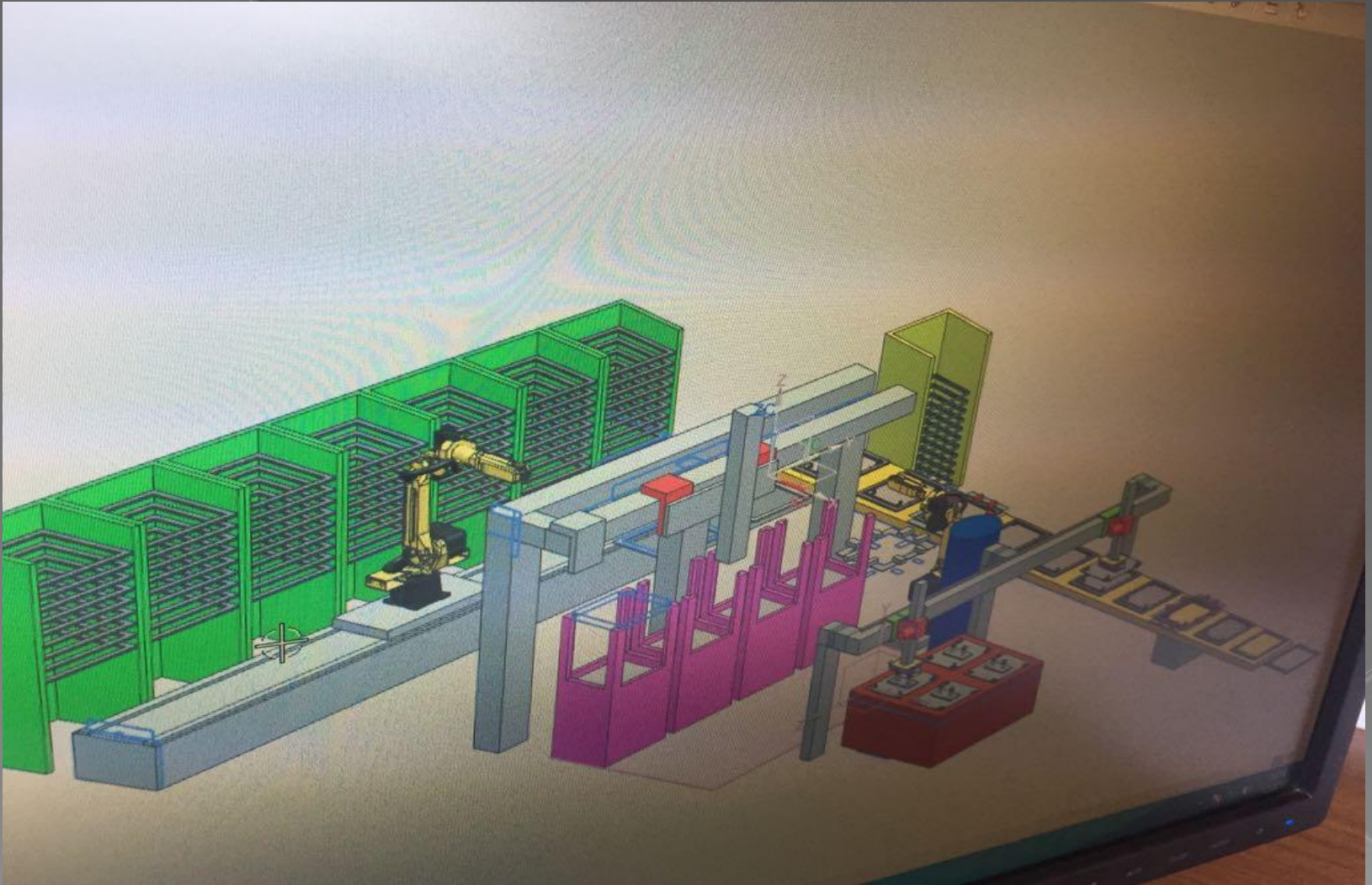

KAMTECH

TEKNOLOJİK MAKİNALAR SANAYİ TİC. LTD .STİ

ROBOT UYGULAMALARI



M-3*i*A DIMENSIONS:
FANUC ROBOT M-3*i*A/6A

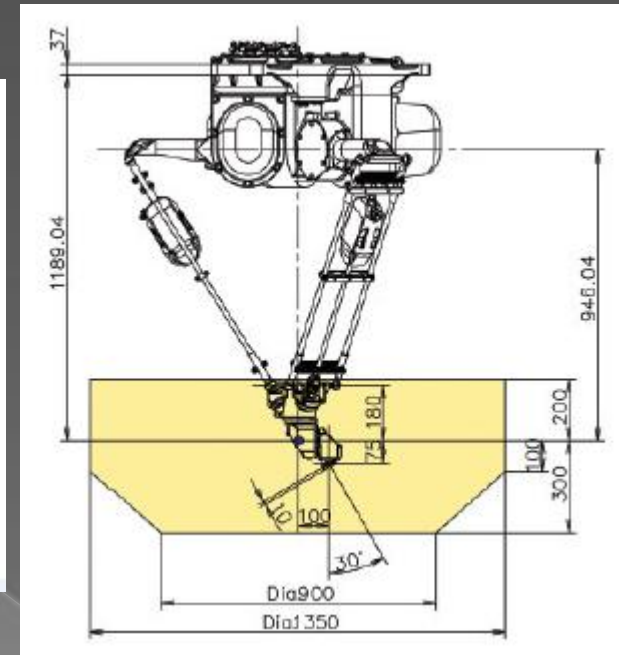
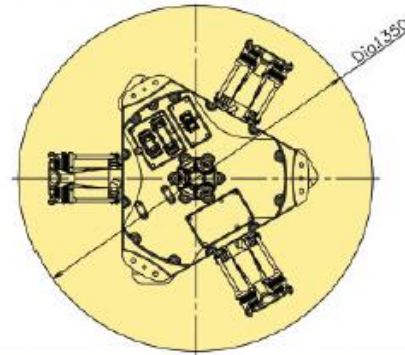

ROBOT UYGULAMALARI

MAXİMUM HIZ İÇİN SİMULASYON ÇALIŞMASI VE ROBOT KULLANIMINA GEÇİŞ

KAPASİTE : 20 kalıp/dk
CYCLE TIME : 6 sn
TOOL AĞIRLIĞI : 80 KG
ÜRÜN AĞIRLIĞI : 5 KG

KALIP BOŞALTMA VE PAKETLEME BESLEME İÇİN
KULLANILAN 4 ADAM/VARDİYA
TOPLAM YILLIK 135 000 € TASARRUF EDİLMİŞTİR

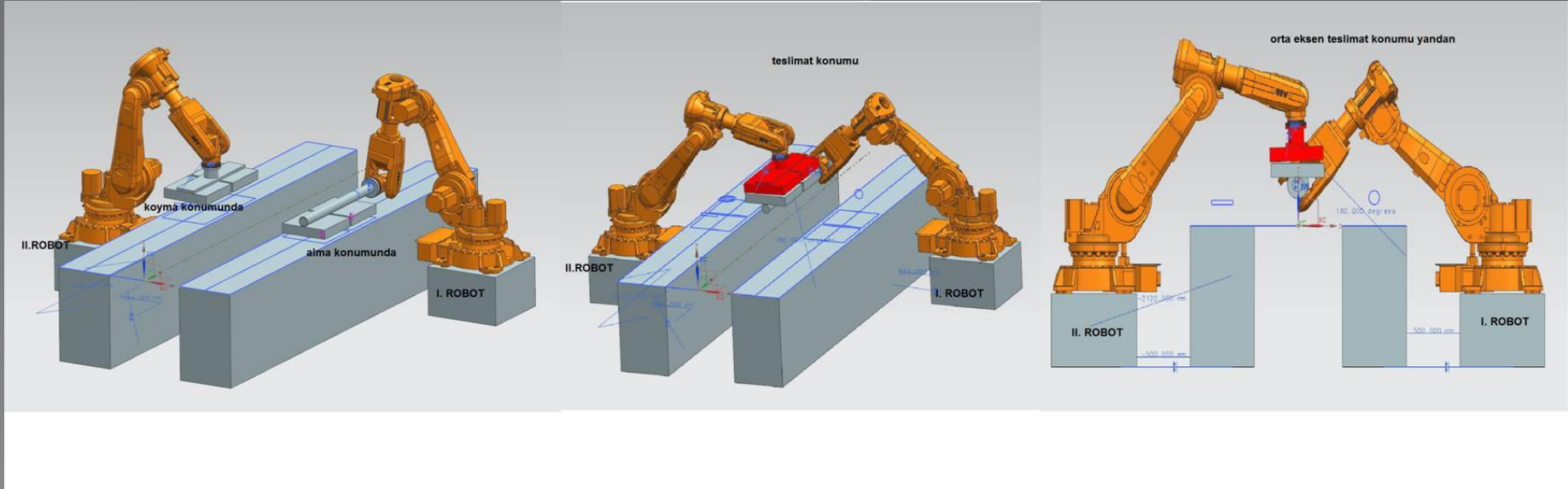

KAMTECH

TEKNOLOJİK MAKİNALAR SANAYİ TİC. LTD. ŞTİ

ROBOT UYGULAMALARI



KAMTECH

TEKNOLOJİK MAKİNALAR SANAYİİ TİC. LTD .STİ

ROBOT UYGULAMALARI



KAMTECH

TEKNOLOJİK MAKİNALAR SANAYİ TİC. LTD .STİ

ROBOT UYGULAMALARI



KAMTECH

TEKNOLOJİK MAKİNALAR SANAYİİ TİC. LTD .STİ

ROBOT UYGULAMALARI



KAMTECH

TEKNOLOJİK MAKİNALAR SANAYİ TİC. LTD. ŞTİ

GRIPPER TASARIMLARI

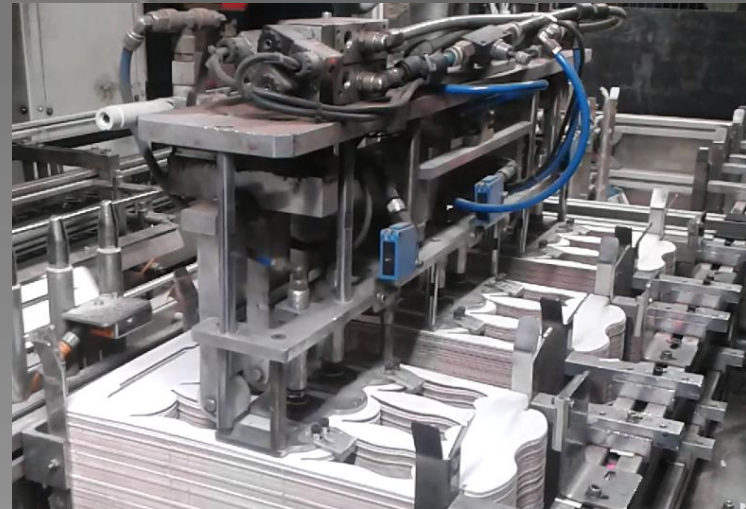
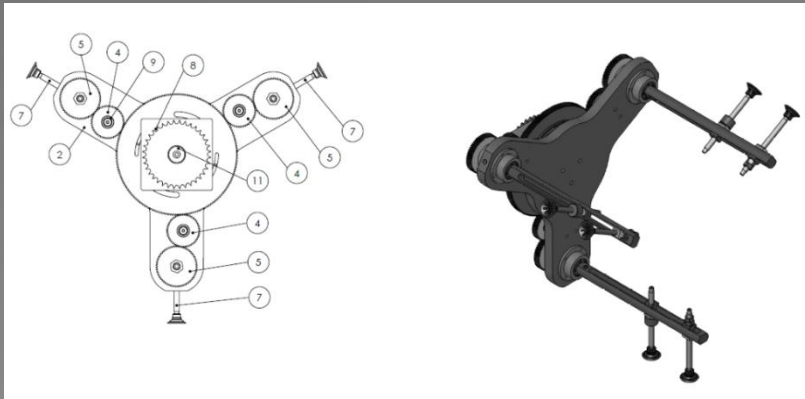

KAMTECH

TEKNOLOJİK MAKİNALAR SANAYİ TİC. LTD .STİ

GRIPPER TASARIMLARI

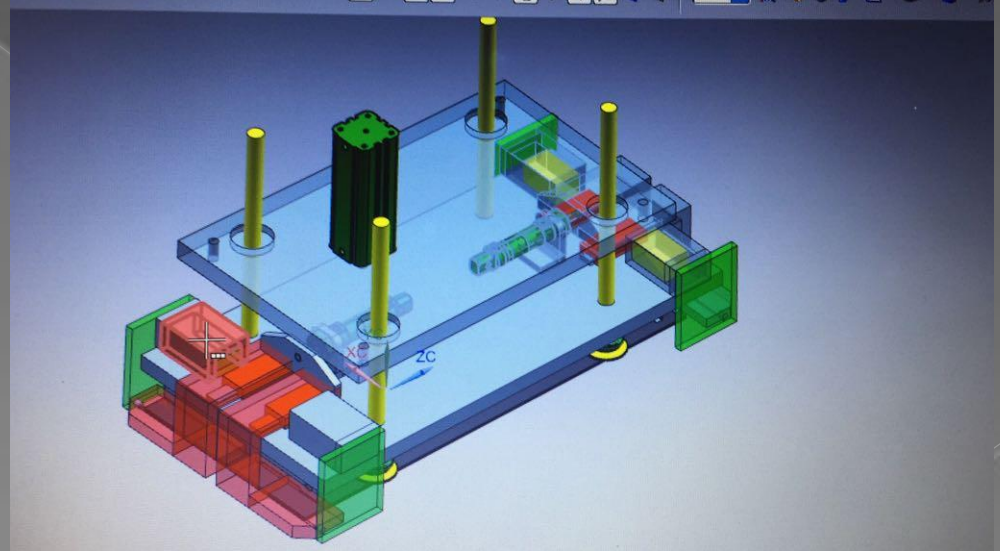
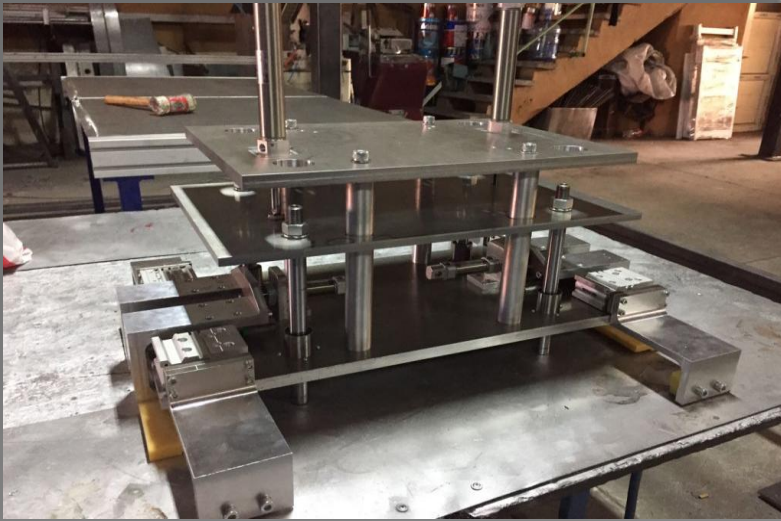

KAMTECH

TEKNOLOJİK MAKİNALAR SANAYİ TİC. LTD .STİ

Prograsif kalıp

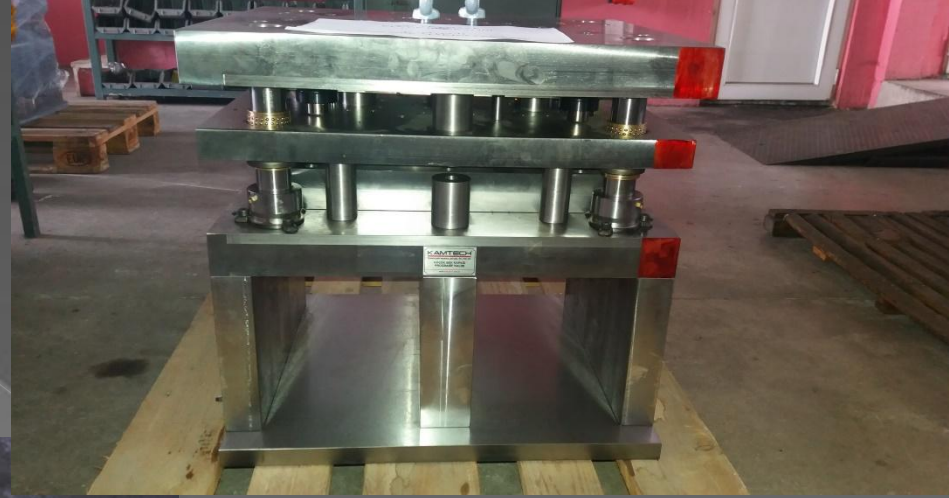

KAMTECH

TEKNOLOJİK MAKİNALAR SANAYİ TİC. LTD .STİ

TABLA TAŞIMA ARABASI



KAMTECH

TEKNOLOJİK MAKİNALAR SANAYİ TİC. LTD .STİ

SAC MAGAZİNLERİ



KAMTECH

TEKNOLOJİK MAKİNALAR SANAYİ TİC. LTD .STİ

Merkezeleme fixtürleri tasarım ve imalat

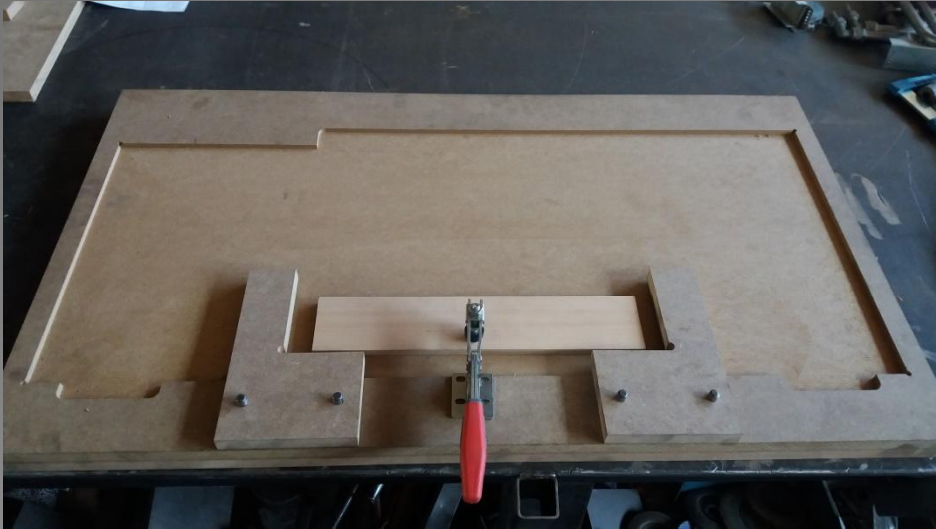

KAMTECH

TEKNOLOJİK MAKİNALAR SANAYİİ TİC. LTD .STİ

Mastar ve Fixture Tasarım ve İmalatı

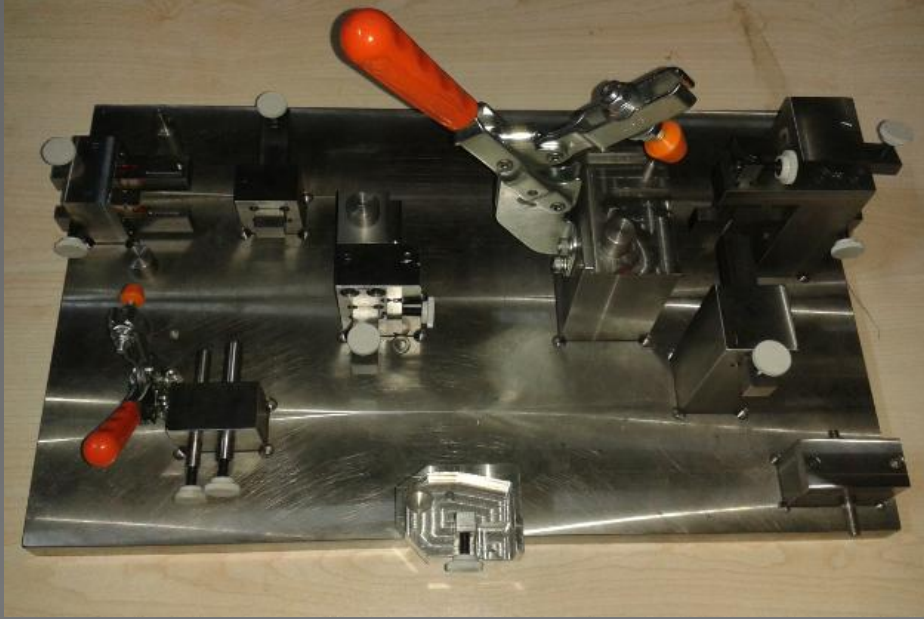

Ateck Gaz Kaçak Test Cihazı Tasarım ve İmalatı

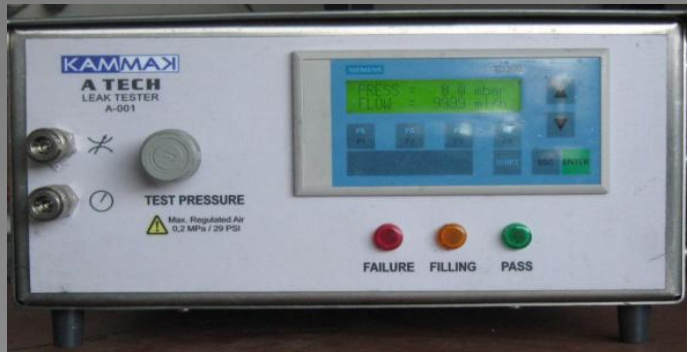

KAMTECH

TEKNOLOJİK MAKİNALAR SANAYİ TİC. LTD .STİ

Punta fixtürü tasarım ve imalatı

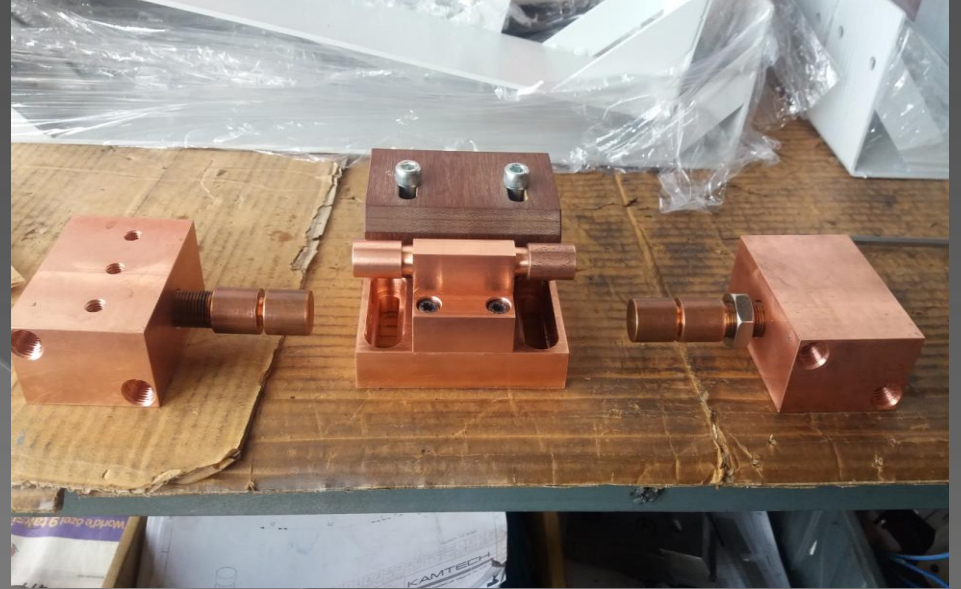
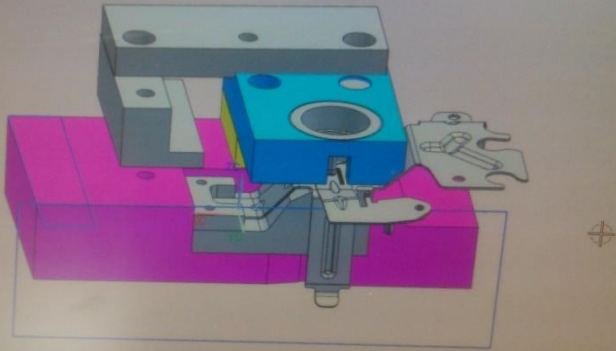

Punta fixtürü tasarım ve imalatı

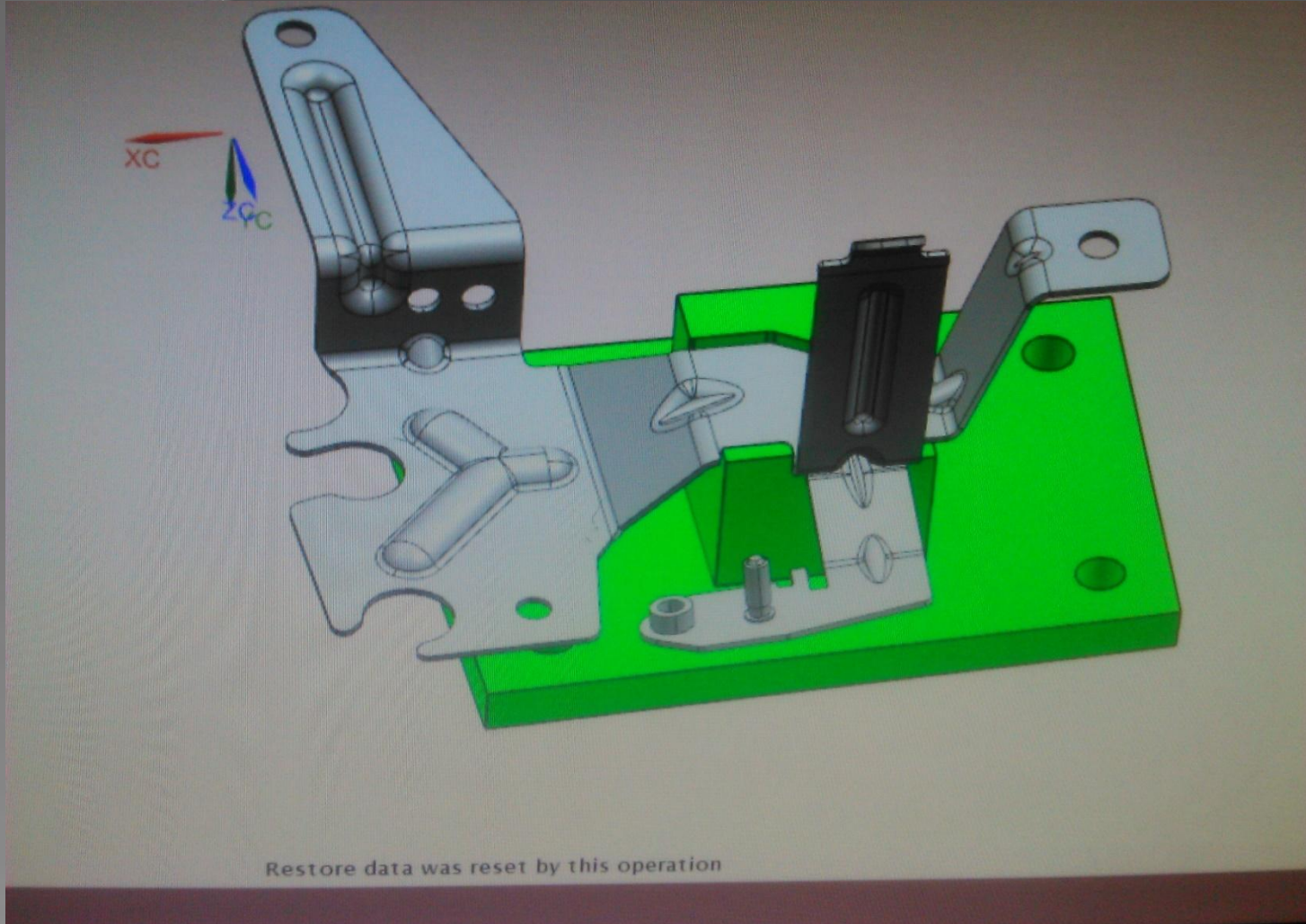

KAMTECH

TEKNOLOJİK MAKİNALAR SANAYİ TİC. LTD .STİ

3D Modelleme

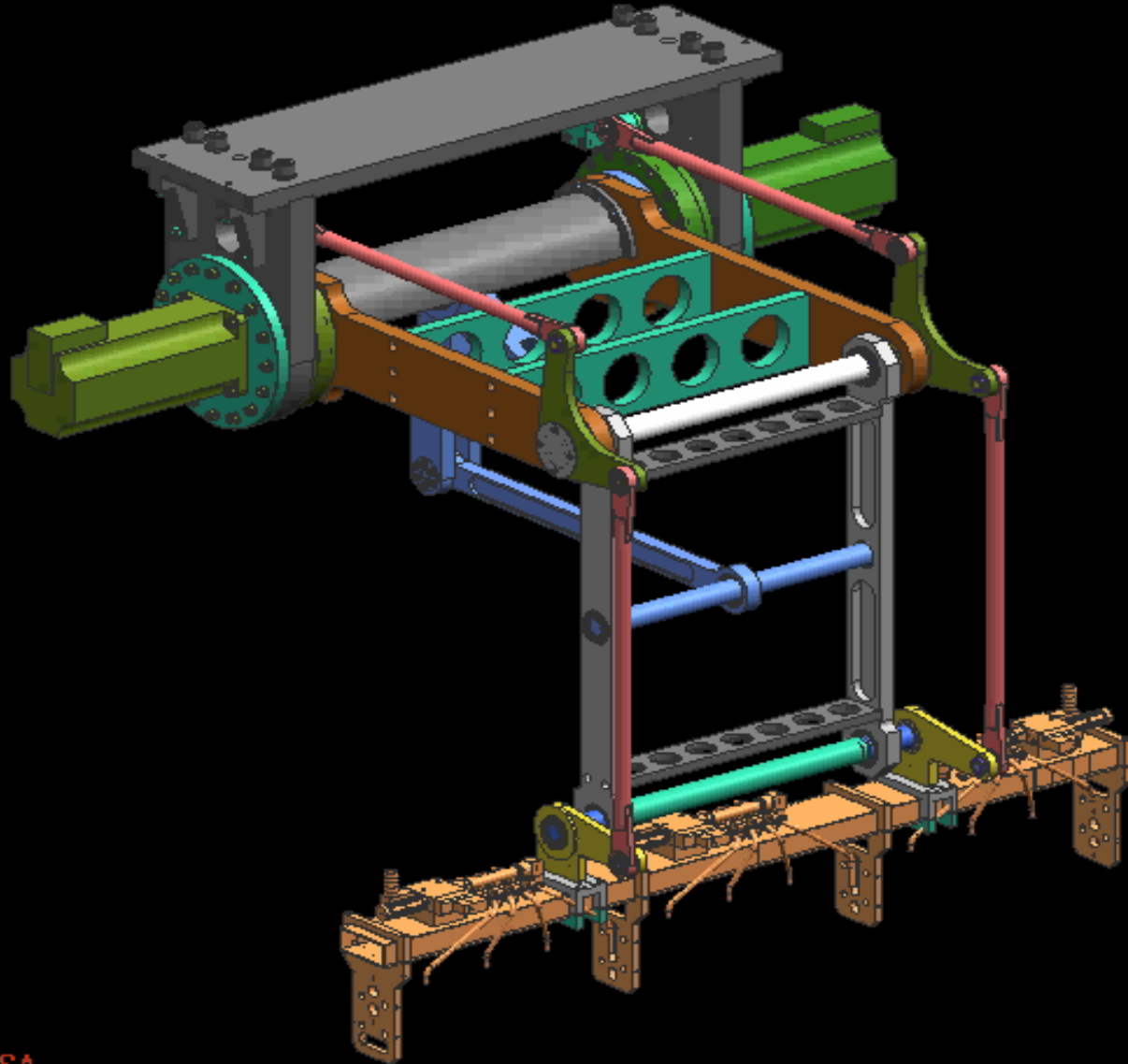

Yapısal Analiz

Model name: A-396.01.01.00.00.00_v1-None
Study name: COSMOSXpressStudy
Plot type: Static nodal stress Plot1
Deformation scale: 515.552

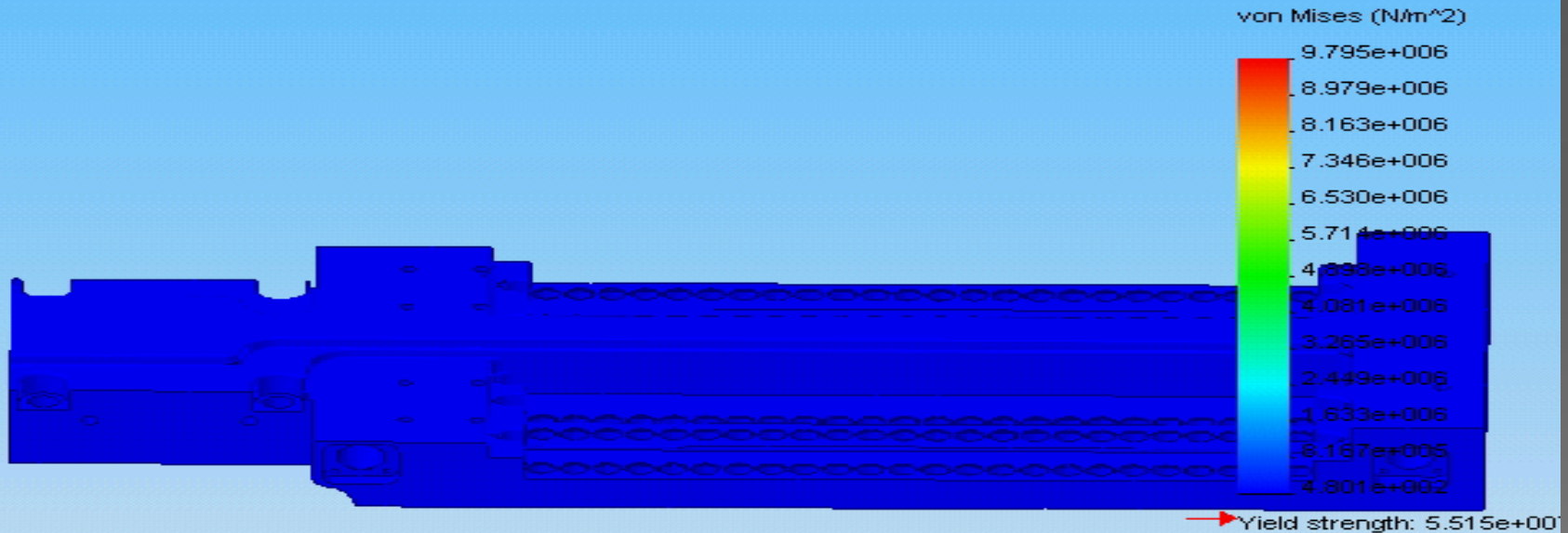

Dinamik Analiz

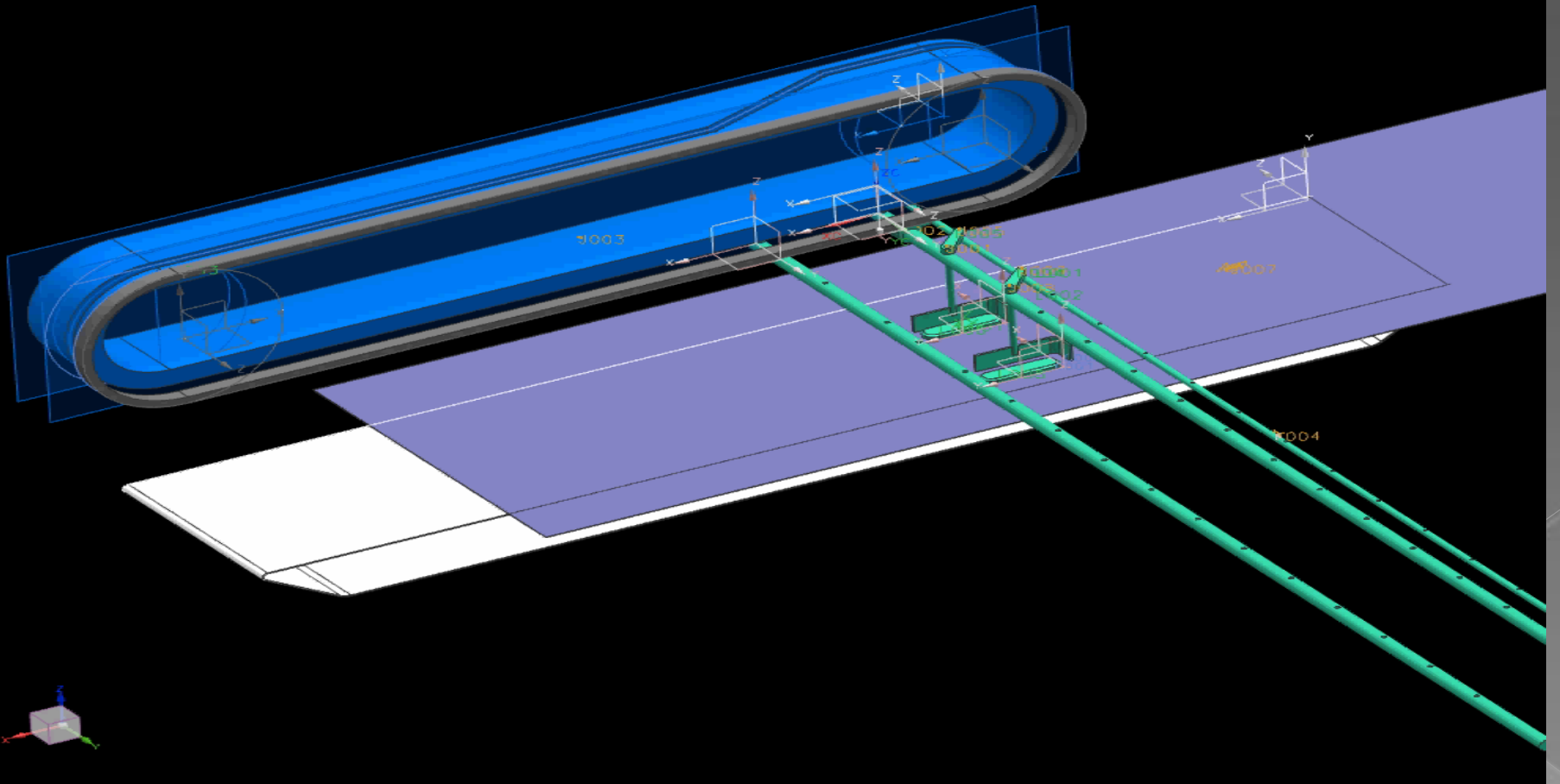

KAMTECH

TEKNOLOJİK MAKİNALAR SANAYİ TİC. LTD .STİ

Kinematik Analiz

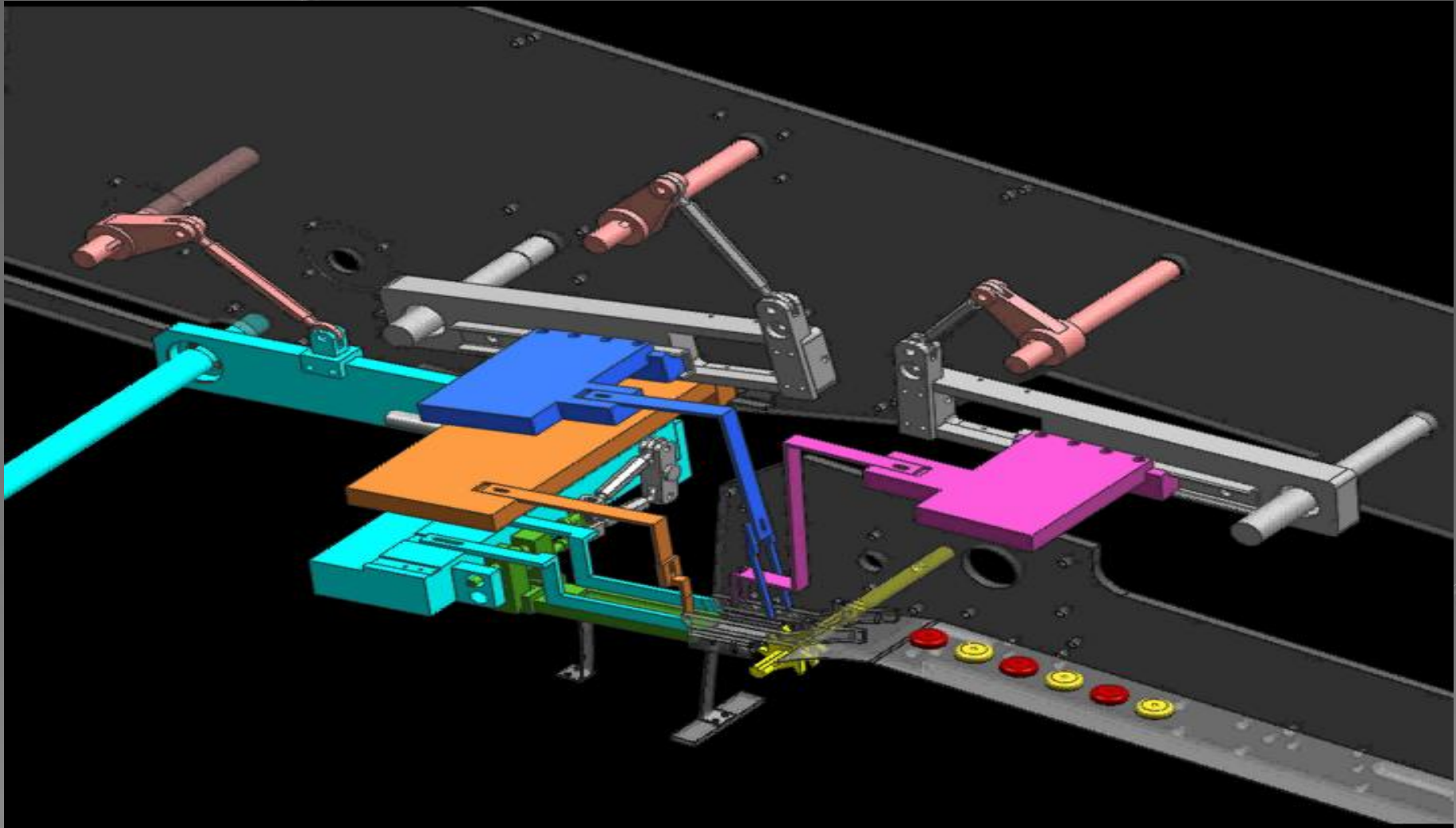

KAMTECH

TEKNOLOJİK MAKİNALAR SANAYİ TİC. LTD .ŞTİ

Ocak Grubu



KAMTECH

TEKNOLOJİK MAKİNALAR SANAYİ TİC. LTD .STİ

Boru Grubu



KAMTECH

TEKNOLOJİK MAKİNALAR SANAYİ TİC. LTD .STİ

MAKİNE PARKI

CNC TEZGAHLARIMIZ



KAMTECH

TEKNOLOJİK MAKİNALAR SANAYİ TİC. LTD .STİ

MAKİNE PARKI

KONVEKSİYONEL TEZGAHLARIMIZ



Referanslar :

- Arçelik
- Vitra
- Pınar Süt
- Candy Hoover
- LAV
- Lanova Ankanstre
- Güral Porselen
- Kar Porselen
- ECA Odöksan A.Ş.
- Can Conta A.Ş.
- Eşçelik A.Ş.
- Esalba A.Ş.
- Güler Metal A.Ş.
- Özer Seramik LTD ŞTİ
- Yafa Kek Cezayir
- Eriş Helva LTD .ŞTİ
- ESCO A.Ş.
- Leibher Bulgaristan Fb.
- Konveyör A.Ş.
- Eti Makine A.Ş.
- Çetintaş Beyaz Eşya A.Ş.
- İran Freezone Amir Asgari

KAMTECH

TEKNOLOJİK MAKİNALAR SANAYİ TİC. LTD .STİ

TEŞEKKÜRLER...